



POD-GL

podion.



PRODUCT SPECIFICATIONS

Height:	820 – 1120mm
Logo Panel:	540mmW x 700mmH (Bottom width 355mm)
Worktop Angle:	10° Incline
Worktop:	630mmW x 450mmD
Footprint:	740mmW x 615mmD
Finish:	Matte Black
Materials:	MDF Worktop Aluminium and Steel Body

(Branding options available on request.)

DESCRIPTION

A mobile gas-lift lectern that functions as both a presentation lectern and a sit-stand desk.

Its lightweight design, compact footprint and adjustable height make it ideal for shared, multi-purpose spaces where mobility and flexibility are key. Ideal for classrooms, training rooms, meeting rooms, workshops, conference breakout spaces and concierge or check-in areas.

KEY FEATURES

- Gas-lift height adjustable
- Inclined worktop with metal rail paper stop
- Mobile base with locking castors
- Built-in storage compartment

DIMENSIONS

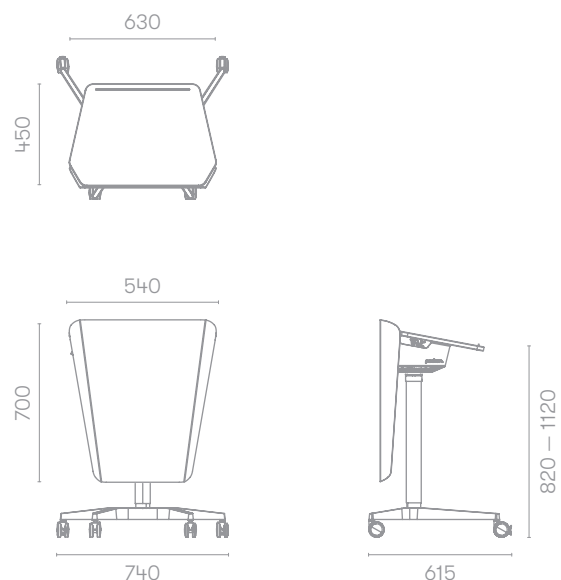

Note: Diagram is set to lowest height.



podionglobal.com
+61 (0)3 9708 6349

PODIUM LECTERNS

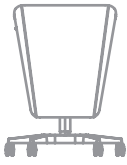

POD-GL

podion.



HEIGHT ADJUSTABLE

Smooth, gas-lift mechanism allows quick adjustment to suit presenters of different heights – no power required.



STORAGE COMPARTMENT

Discreetly positioned under the worktop for notes, small devices and accessories.

BRANDING OPTIONS

Branding: Vinyl wraps, decals, or cut-outs
Interchangeable magnetic signage
Non-standard colours and finishes



podionglobal.com
+61 (0)3 9708 6349

PODIUM LECTERNS