

## DESCRIPTION

The POD-MPS redefines versatility as a premium, height-adjustable workstation for presentations and countless tilt-enabled applications. This sleek, mobile unit seamlessly adapts from a commanding lecture platform to an ergonomic, portable desktop optimized for professionals.

Its lightweight yet durable design empowers architects, artists, and educators with a flexible, tilt-capable workspace ideal for reviewing plans, annotating displays, or any task requiring an adjustable surface angle. With sophisticated style and uncompromising functionality, the POD-MPS unlocks new creative and productive possibilities wherever you work.

## KEY FEATURES

- Tilt bench top
- Equipment shelf
- Book stop strip
- Modesty logo panel
- Lockable castors
- Bag hook



PRODUCT NAME:	POD-MPS
PRODUCT DESCRIPTION:	MOBILE PRESENTATION STATION
PRODUCT CATEGORY:	GAS LIFT/PODIUM LECTERNS
OVERALL FOOTPRINT:	600mm-780mm(24"-30")
HEIGHT:	700mm-1000mm(27"-39")
BENCH TOP DIMENSIONS:	600 X 780mm(24"X30")
WEIGHT:	25kg(55lbs)
MATERIALS:	LAMINATE BENCH TOP, ALUMINIUM AND STEEL BODY
LOGO PANEL DIMENSIONS:	650mm x 300mm (25inch x 12inch)
EQUIPMENT STORAGE:	LOWER SHELF 400mm x 220mm (16inch x 9inch)
COLORS/FINISHES:	MATTE BLACK/WHITE

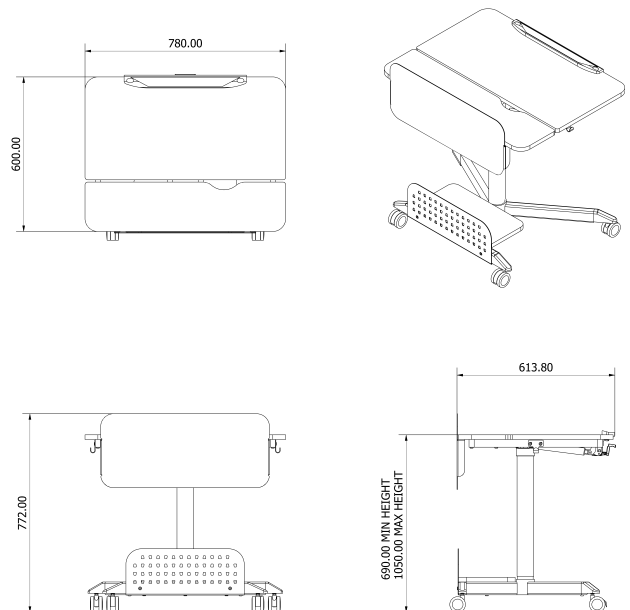

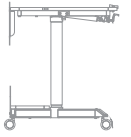

### TILTING TABLETOP

The 780mmW x 400mmW adjustable top switches between a flat surface for writing or typing and an 60° angle for reading or drawing.

Laminated MDF top offers a scratch resistant surface that resists moisture and staining, guaranteeing easy maintenance and longevity. Curved design eliminates sharp corners for safety.



### STORAGE SHELF

The strategically placed shelf provides discreet storage, ensuring items remain accessible yet unseen by the audience. A perforated privacy shield enhances the modern look of this lectern.

